

www.krw.de

KRW Leipzig

Bearings for Roller Presses

Product range

Raw Material Extraction and Processing

Bearings for Roller Presses

Roller presses are often used for comminuting medium-hard to hard materials such as ores, coal, cement or other mineral materials.

The design of these crushers is similar to that of roll crushers or high-pressure grinding mills. Two rolls of the same size rotate at the same circumferential speed. This set-up results in a higher throughput of material and a higher efficiency. Compared to other crushing machines, a roller press also has a double-digit energy-saving potential in the medium range. This makes it the best solution ecologically and economically wise.

Part of the energy saving are the result of the use of application-optimized rolling bearings. For this reason, high-performance roller press manufacturers rely on the proven quality of KRW rolling bearings. KRW supports customers from the initial idea until the launch of series production as well as spare parts requirements with high competence and many years of experience.

Roller presses are always equipped with a fixed-floating bearing to compensate for expansion that occurs as a result of the heat working process. Mainly rolling bearings are installed that are suitable for absorbing high radial and axial loads. Depending on the size of the roller press, spherical roller bearings or a combination of two four-row cylindrical roller bearings and two axial spherical roller bearings are used.



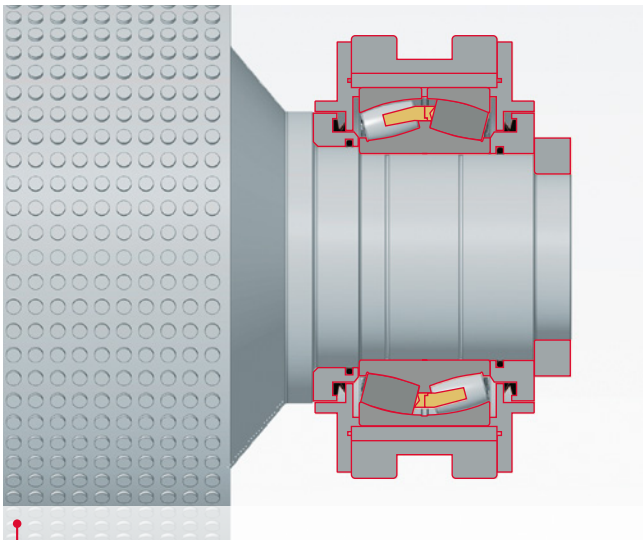

Bearing arrangement of Spherical Roller Bearings

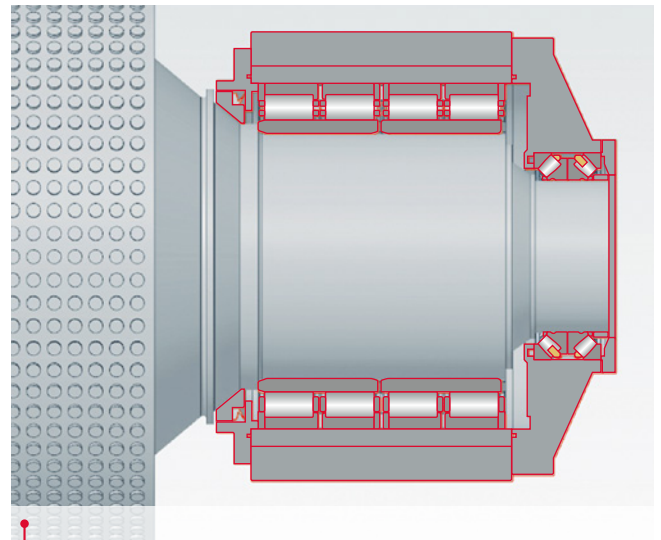

Bearing arrangement Multi Row Cylindrical Roller Bearing with Spherical Roller Thrust Bearing (fixed/non-locating bearing)

The length compensation for spherical roller bearings is carried out via the lateral surface of the bearing. Therefore, jamming may occur due to fretting corrosion or other inhibiting interference factors. For this reason, KRW recommends the use of cylindrical roller bearings in which the length compensation in the bearing is carried out during the rotating motion.

The fixed bearing consists of two components. Two spherical roller thrust bearings in an X arrangement can carry thrust from two directions. It is important that the bearings are radially retained and axial preloaded with springs. The combinations of a four-row cylindrical roller bearing as a radial bearing, the result in an extremely high-performance fixed bearing.

Due to the continuous development of bearings used in roller presses, it is possible to increase the service life even with the same mounting space. The four-row cylindrical roller bearings, for example, are equipped with the largest possible number of rolling elements. This is only possible through the use of pin cages and hollow-bored rollers. Through application-specific heat treatment and the optimized surface microstructure of the components. KRW implements the best possible solution for its customer.

Trust in the know-how of KRW

- ▶ Our technology is always up-to-date.
In addition to the service life calculations (according to ISO281) and the reference service life calculations (according to ISO/TS16281), FE analyses of individual components can also be arranged.
- ▶ We help you to select the right lubricant.

- ▶ We support your assembly team in the hydraulic and thermal mounting and dismantling of rolling bearings.
- ▶ We perform vibration analyses of bearings to define necessary maintenance measures at an early stage.
- ▶ We help with the analysis of damaged KRW bearings as well as bearings of other well-known manufacturers.

Multi Row Cylindrical Roller Bearings

Bearings for Roller Presses

- ▶ Absorption of very high radial loads
- ▶ Precise shaft guidance with high rigidity
- ▶ Inner and outer rings with roller cage assembly available separately

Description	Dimensions [mm]						Load Rating [kN]		Mass [kg]
	d	D	B	F	r _{3,4}	r _{1,2}	C _r	C _{0r}	m
12.49.12	500	710	480	558	5	17x20°	14740	25800	620
12.59.05	600	820	550	660	3	18x20°	18570	32900	870
12.64.04	650	900	650	715	7,5	20x20°	24840	45700	1300
12.70.03	710	1000	715	787,5	4	22x20°	30400	55265	1845
12.85.02	850	1150	840	928	4	23x20°	40470	77000	2575
12.89.05	900	1280	930	1000	4	25x20°	48150	98120	4011

Dimensions of D₁, D_a, d_a, r_g are available on request.

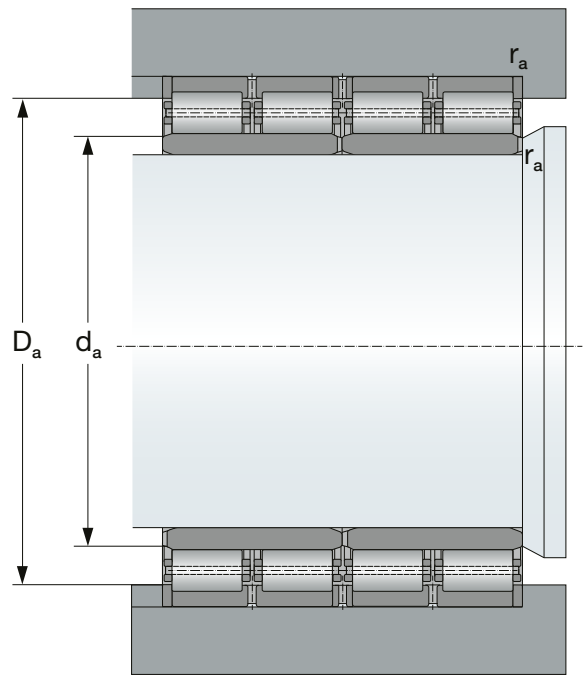
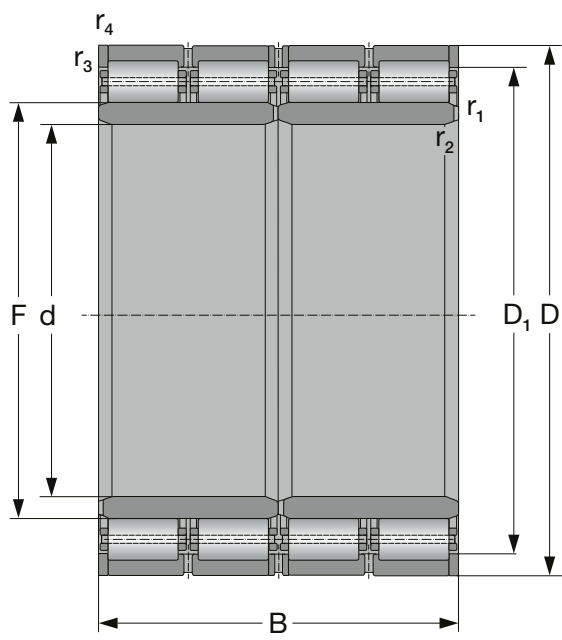

Spherical Roller Bearings (radial)

Bearings for Roller Presses

- ▶ Compensation of angular misalignments
- ▶ Absorption of high radial and axial forces from both directions
- ▶ Suitable for medium speeds

Description	Main dimensions [mm]			Load Rating [kN]		Fatigue Limit Load [kN]	Rotational speed [min ⁻¹]		Mass [kg]
				dyn.	stat.		Reference speed	Limiting speed	
	d	D	B	C	C ₀	C _u	n _{th}	n _g	
23176EA.S.M	380	620	194	4050	7750	530	526	950	237
24176EA.S.M	380	620	243	5100	9900	678	323	850	296
23192EA.S.M	460	760	240	5900	11500	748	402	740	444
24192EA.S.M	460	760	300	7350	14800	965	240	670	559
231/500EA.S.M	500	830	264	7000	13800	879	355	660	587
241/560EA.S.M	560	920	355	10600	21700	1348	175	520	965
231/750EA.S.M	750	1220	365	13800	29000	1679	197	400	1728
241/750EA.S.M	750	1220	475	17500	37600	2181	114	360	2228
241/900EA.S.M	900	1420	515	21600	49300	2749	100	280	3173

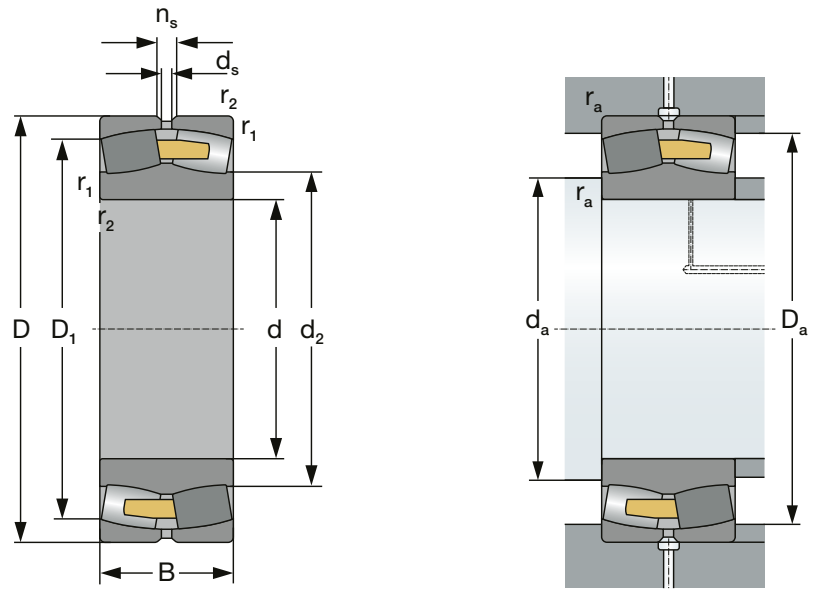

Measurements [mm]					Mating dimensions [mm]			Calculation factor			
d_2	D_1	d_s	n_s	$r_{1,2}$	$d_{a, \min}$	$D_{a, \max}$	$r_{a, \max}$	e	Y_1	Y_2	Y_3
453,7	540,2	12,5	23,5	5	400	600	4	0,29	2,32	3,45	2,26
444,8	531	9,5	17,7	5	400	600	4	0,38	1,79	2,67	1,75
556,4	665	12,5	23,5	7,5	492	728	6	0,3	2,28	3,39	2,23
542,9	646,8	12,5	23,5	7,5	492	728	6	0,38	1,78	2,65	1,74
606,7	725,5	12,5	23,5	7,5	532	798	6	0,3	2,25	3,34	2,2
664	793,2	12,5	23,5	7,5	592	888	6	0,36	1,87	2,79	1,83
902,6	1075,8	12,5	23,5	9,5	790	1180	8	0,28	2,37	3,53	2,32
876,8	1046,2	12,5	23,5	9,5	790	1180	8	0,38	1,79	2,67	1,75
1001,8	1231,4	12,5	23,5	12	948	1372	10	0,35	1,95	2,9	1,91

Note: All above listed KRW bearings are also available in a conical design.

Spherical Roller Thrust Bearings (axial)

Bearings for Roller Presses

- ▶ Compensation of angular misalignments
- ▶ Absorption of high axial forces from one direction
- ▶ Suitable for medium speeds

Description	Main dimensions [mm]			Load Rating [kN]		Fatigue Limit Load [kN]	Rotational speed [min ⁻¹]		Mass [kg]
				dyn.	stat.		Reference speed	Limiting speed	
	d	D	B	C	C ₀	C _u	n _{th}	n _g	
29256EA.MB	280	380	60	1040	4700	405	935	1700	18,9
29272EA.MB	360	500	85	1840	8500	690	671	1200	48,9
29276EA.MB	380	520	85	1920	9100	730	628	1200	51,3
29284EA.MB	420	580	95	2230	10800	845	566	990	72,6
292/560EA.MB	560	750	115	3440	18100	1330	386	760	139

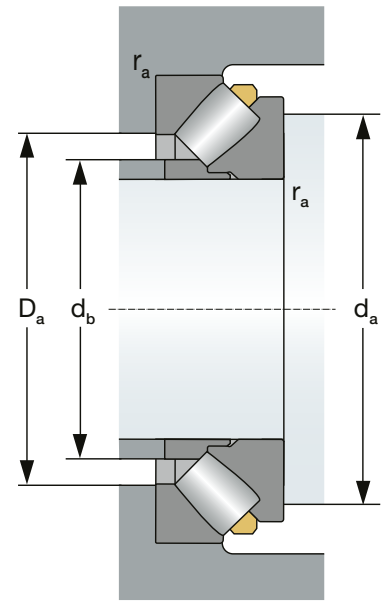
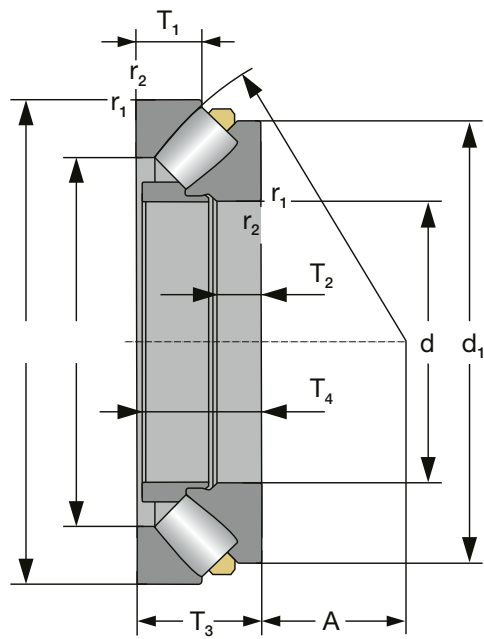

Measurements [mm]								Mating dimensions [mm]			
d_2	D_1	d_s	n_s	$r_{1,2}$	$d_{a,min}$	$D_{a,max}$	$r_{a,max}$	$d_{a,min}$	$d_{b,max}$	$D_{a,max}$	$r_{a,max}$
360	323	30,5	22	38	57	150	2,1	330	293	351	2,1
470	423	44	31	51	81	194	4	430	379	461	3
490	441	42	31	53	81	202	4	445	394	480	3
545	489	46	34	58,5	91	225	5	495	439	534	4
715	644	61	41	71	111	302	5	655	587	697	4

Do you have any questions or need further information about our products?
Our sales team will be happy to assist you with any request.

+49 (0)341 45320-200

sales@krw.de

Service and Engineering

In addition to the common standard rolling bearing types, the KRW portfolio offers an extensive range of special bearings for individual bearing solutions. Our application engineers will support you from the selection and configuration of the best rolling bearing solution through to assembly and disassembly on your site.



Close up of a material fatigue damage

Mounting support

Preliminary damage during assembly or handling of rolling bearings is the second most common cause of premature bearing failure after lubrication. Large and heavy rolling bearings in particular are not easy to assemble. They can be easily damaged by carelessness, improper transport, or errors made during assembly.

Avoid these unnecessary problems and costs! Our engineers will advise you before the installation of the bearing and help you to avoid initial mistakes. We will recommend the best assembly strategy and will be there to support you on site.

Diagnosis and damage analysis

Rolling bearings are by far among the most heavily stressed machine components. When there are mechanical problems, therefore, the most obvious signs and the heaviest damage are often found on the bearings.

However, the rolling bearing itself is only rarely the cause. We help you to find the cause of the bearing failure and to avoid future damage.

Take advantage of our experience and our extensive capabilities:

- Visual bearing diagnosis
- Lubricant analysis
- Metallographic testing and evaluation of rolling bearings
- Metrological analysis of all components
- Measurement of form deviations and surface structures of rolling bearing components
- SEM analysis to detect elements, for example, or current passage
- Design- and calculation-based verification of the bearing arrangement
- FE analysis of machine components and strength analysis

The experienced KRW application technology team will be pleased to support you.

Quality and Certification

High-precision rolling bearings require first-class quality. This is ensured by our innovative manufacturing processes, our quality management system, and our high standards of occupational safety and environmental protection. Quality assurance is an important part of our manufacturing process and is supported with regular audits. This allows us to guarantee our customers consistently exceptional product quality.

Materials testing

In addition to material technology tests such as hardness testing, metallographic testing to identify the chemical composition, determine the degree of purity, and assess the microstructure have become standard for rolling bearing applications.

Ultrasonic, magnetic particle, eddy current, and grinding burn tests are also carried out in our in-house materials testing laboratory. This enables us to ensure the quality of the materials before and after heat treatment.

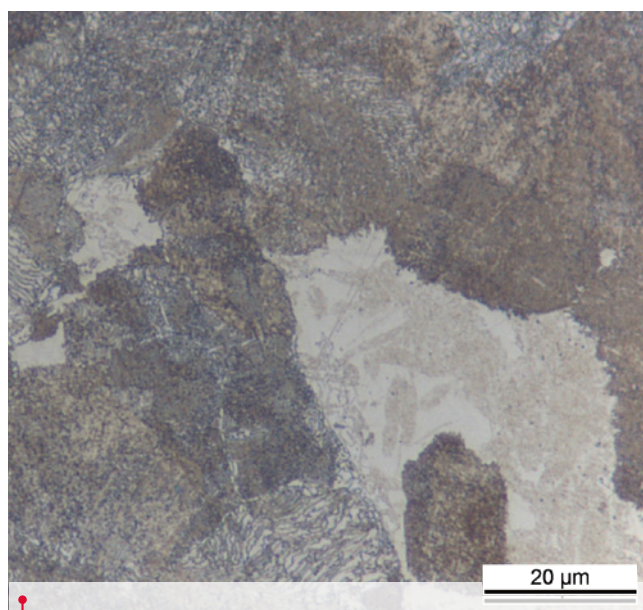

Microstructure of a rolling bearing component



Certified quality

Our quality management is certified according to DIN EN ISO 9001. In addition, the KRW energy management system meets the high requirements of DIN EN ISO 50001.

As a Q1 supplier of Deutsche Bahn with manufacturer-related product qualification (HPQ), KRW has been qualified to supply safety-relevant components such as wheelset bearings for more than ten years.

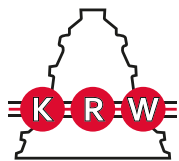

**Kugel- und Rollenlagerwerk
Leipzig GmbH**

Gutenbergstraße 6
04178 Leipzig
Germany

Phone +49 (0) 341 45320-200
Fax +49 (0) 341 45320-201
E-mail sales@krw.de

www.krw.de